

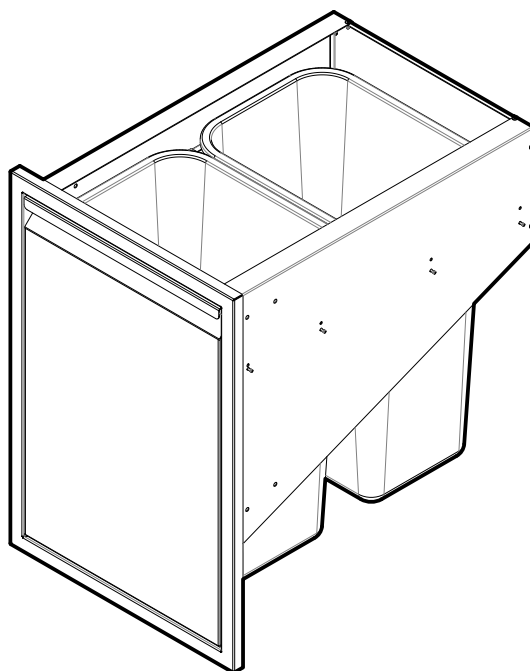

# TWIN EAGLES 18" TALL DOUBLE TRASH DRAWER FEATURE SHEET



## TETD182T-B

### FEATURES:

- 304 Stainless Steel construction
- Heavy duty, 100 lbs capacity, full extension and self-closing removable slides
- Non-protruding flush door handle design with high-polished accents
- One-piece 18 gauge front frame
- Accommodates two separate trash container for Waste and for Recycling
- Trash containers included
- Easy to install

### SPECIFICATIONS:

- Overall Dimensions:

	TETD182T-B
Height:	26.00"
Width:	18.00"
Depth:	24.50"
Ship Weight:	85 lbs
- Cutout Dimensions

Height:	24.25"
Width:	16.5"
Depth:	n/a



#### WARNING

PROP. 65 FOR CALIFORNIA RESIDENTS  
Cancer and Reproductive Harm -- [www.P65Warnings.ca.gov](http://www.P65Warnings.ca.gov)



#### AVERTISSEMENT

PROP. 65 POUR LES RESIDENTS DE LA CALIFORNIE  
Cancer et Troubles de l'appareil Reproducteur -- [www.P65Warnings.ca.gov](http://www.P65Warnings.ca.gov)